

(No Model.)

2 Sheets—Sheet 1.

F. RAMACCIOTTI.

SPINNING LATHE FOR WINDING PIANO STRINGS.

No. 280,512.

Patented July 3, 1883.

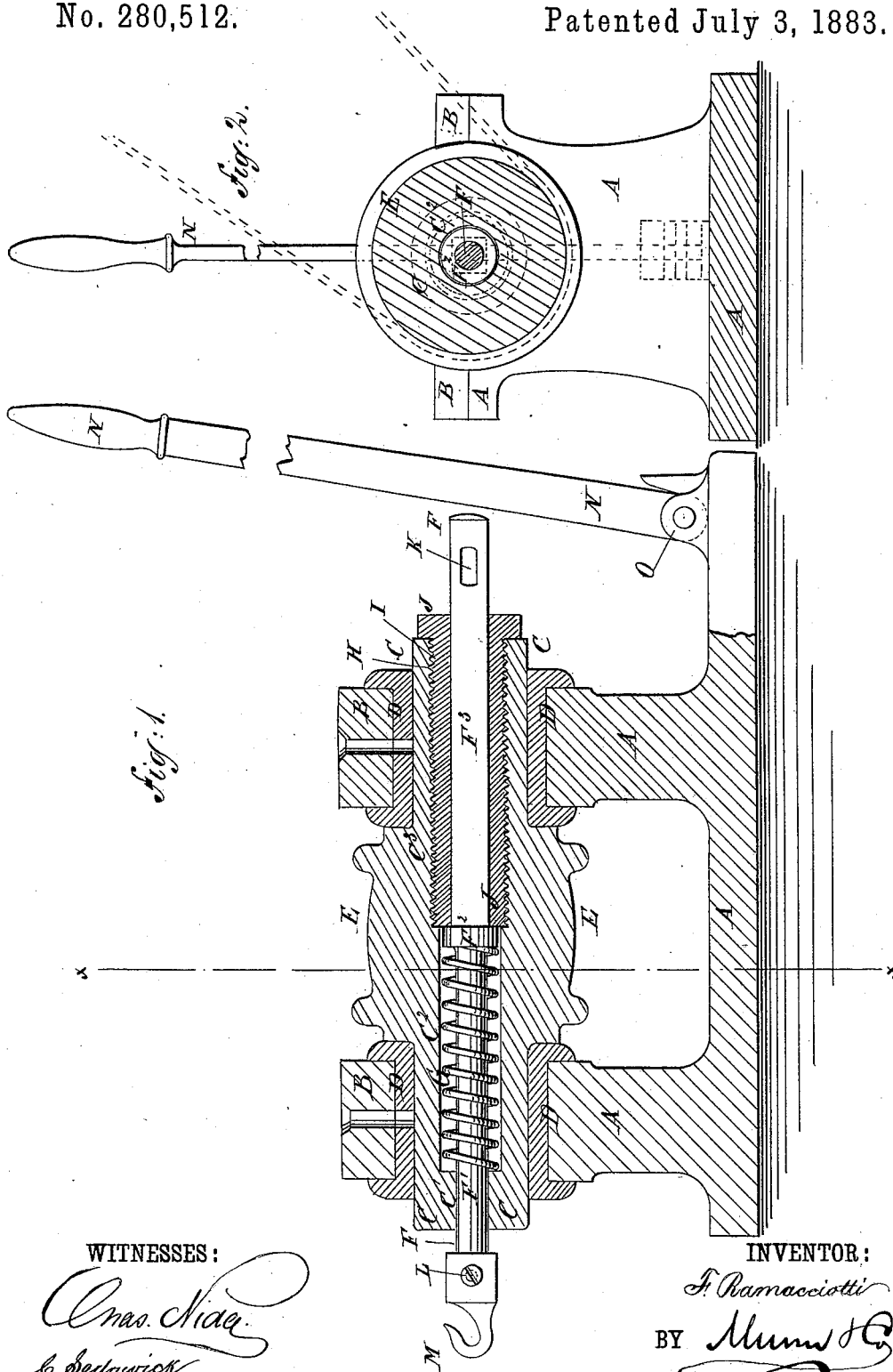

WITNESSES:

Chas. Nida.
C. Sedgwick

INVENTOR:

F. Ramacciotti
 BY *Munn & Co.*
 ATTORNEYS.

(No Model.)

2 Sheets—Sheet 2.

F. RAMACCIOTTI.

SPINNING LATHE FOR WINDING PIANO STRINGS.

No. 280,512.

Patented July 3, 1883.

Fig. 3.

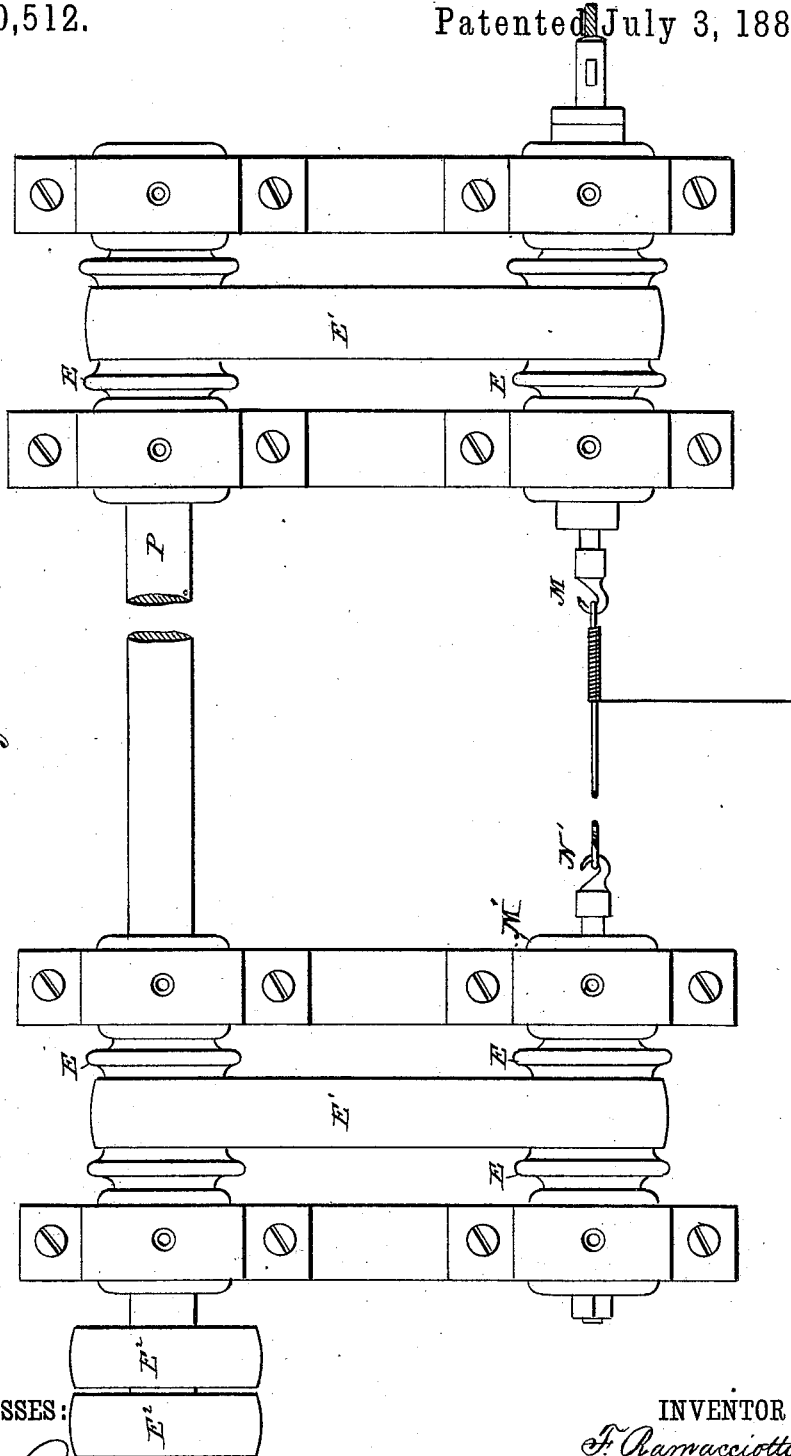

WITNESSES:

Chas. Nida
C. Sedgwick

INVENTOR:

F. Ramacciotti

BY

Munn & Co

ATTORNEYS.

UNITED STATES PATENT OFFICE.

FRANCIS RAMACCIOTTI, OF NEW YORK, N. Y.

SPINNING LATHES FOR WINDING PIANO-STRINGS.

SPECIFICATION forming part of Letters Patent No. 280,512, dated July 3, 1883.

Application filed November 23, 1882. (No model.)

To all whom it may concern:

Be it known that I, FRANCIS RAMACCIOTTI, of the city, county, and State of New York, have invented a new and useful Improvement in Spinning Lathes for Winding Piano-Strings, of which the following is a full, clear, and exact description.

Reference is to be had to the accompanying drawings, forming part of this specification, in which similar letters of reference indicate corresponding parts in all the figures.

Figure 1 is a sectional side elevation of my improvement. Fig. 2 is a sectional end elevation of the same, taken through the line *x x*, Fig. 1. Fig. 3 is a plan view, showing the hook mechanism and means for revolving it.

The object of this invention is to secure uniformity of tension in the main or center wire when winding piano-strings.

A represents the frame of the machine. In bearings B in the frame A revolve the journals of the spindle C, which bearings are provided with anti-friction boxes D, in the ordinary manner.

Upon the middle part of the spindle C is formed, or to it is attached, a pulley, E, to receive the driving-belt. The spindle C is perforated longitudinally to receive the center F. The forward part, C', of the perforation is made small, to receive and serve as a bearing for the cylindrical forward part, F', of the center F. The part C' of the perforation is made short, and from its inner end, to or beyond the center of the spindle, is formed the second part, C², of the said perforation, which is made so much larger than the cylindrical part F' of the center F as to form space for the spiral spring G, placed upon the said cylindrical part F' of the center F. The forward end of the spiral spring G rests against the shoulder in the spindle C at the forward end of the part C² of the perforation, and its rear end rests against a collar, F², formed upon or attached to the center F at the rear end of its cylindrical part F'. The rear part, C³, of the perforation in the spindle C is made larger than the second part, C², and has a screw-thread, H, formed upon its inner surface, to receive the screw-thread I, formed upon the outer surface of the bushing J, which has a square perforation formed through it to receive the square rear part, F³, of the center F, so that the said bushing J can be screwed in and out by turning the said center F. The projecting rear end of the center

F has a short slot, K, formed through it to re-

ceive a lever for turning the said center F to screw the bushing J in and out. With this construction the spindle C will carry the center F with it in its revolution, the screw-threads H I being so formed that the revolving movement of the spindle C will tend to screw the bushing J inward, and thus prevent the said bushing from working out. The center F is pushed forward to compress the spring G and allow the wire to be readily attached to and removed from the hook M by a lever, N, the lower end of which is hinged to a support, O, attached to the bed-plate of the machine in such a position that the said lever, when swung forward, will rest squarely against the rear end of the said center F.

One end of the string to be wound is attached to the hook M, and the other end to a similar hook, N', revolving in bearings M', and provided with a pulley, E, corresponding with the pulley E on shaft P. Around these pulleys and those on shaft P pass two belts, E'. The shaft P is also provided with a fast and a loose pulley, E² E³, to receive the driving-belt, so that the hooks M, carrying the wire, will be revolved at the same speed to keep the longitudinal wire straight and wind the covering-wire upon it. The outer wire is fed to and wound upon the central wire in the ordinary manner as the said central wire is revolved by the spinning lathe.

Having thus described my invention, I claim as new and desire to secure by Letters Patent—

1. The combination of a rotary spindle having graduated perforations with a longitudinal sliding center, a screw-bushing, and a tension-spring, all arranged in a spinning lathe, as described.

2. The combination, with the tension-spring G, and the spindle having perforations *c' c² c³*, of the center F, having the cylindrical part F', square part F³, and the center part, F², as and for the purpose specified.

3. The combination, with the spindle C, having interior screw-thread, H, and the sliding center F, having square rear part, F³, and collar F², of the bushing J, having exterior screw-thread and square interior, substantially as herein shown and described, whereby the said center is held from turning within the spindle and the rearward movement of the said center is limited, as set forth.

Witnesses: FRANCIS RAMACCIOTTI.

JAMES T. GRAHAM,
C. SEDGWICK.